

Part number

# CAP 10.229

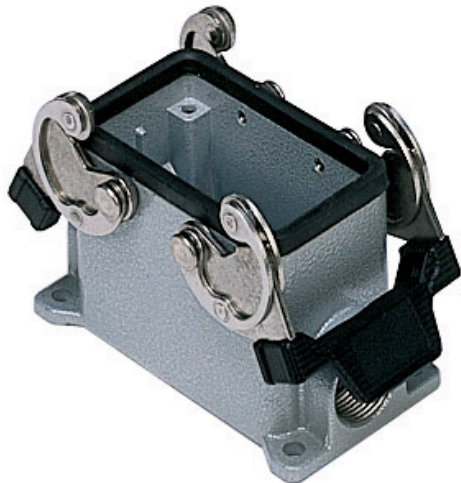

## Brief description:

surface mounting housings with 2 levers, size "57.27", Pg29 x 2, metal version, IP66

### Product description

Version	metal version
Series	surface mounting housings with 2 levers
Product type	with 2 levers
Style	high construction
Family	CLASS enclosures
Size	size "57.27"

### Technical data

Material	metal
IP degree of protection	IP66 (and IP69K DIN 40050 - 9)
Cable entry	Pg29 x 2

### Further technical details

Weight	315,00 g
--------	----------

### Approvals / Standards

Quality mark	 (type:4/4X/12),  , EAC
Conformity	CQC, CE

### General ordering information

EAN13 code	8015747007849
Tariff number	85369095

### Packaging Information

Packaging length	475,00 mm
Packaging height	200,00 mm
Packaging width	150,00 mm
Packaging weight	3,15 kg
Packaging volume	14,25 dm <sup>3</sup>
Packaging description	Carton box
Packaging quantity	10 Pcs
Packaging EAN code	8015747236454
Sub-packaging weight	1,58 kg
Sub-packaging description	Plastic packaging
Sub-packaging quantity	5 Pcs
Sub-packaging EAN barcode	8015747007856

Part number

# CAP 10.229

Catalogue drawings

## CHP CAP - MHP MAP

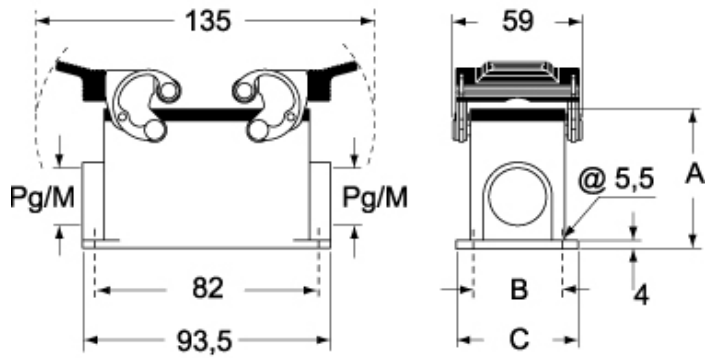

## CHP CS/CP CAP CS/CP - MHP CS/CP MAP CS/CP

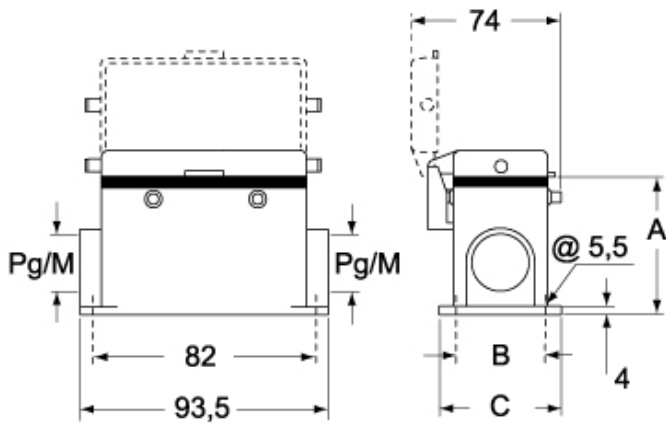

	A	B	C
CHP L / MHP L	57	40	52
CAP L / MAP L	73	45	57
CHP CS / MHP CS	57	40	52
CAP CS / MAP CS	73	45	57
CHP CP / MHP CP	57	40	52
CAP CP / MAP CP	73	45	57